

DATASHEET

Mutica

SR42W001 • lamiiANT®

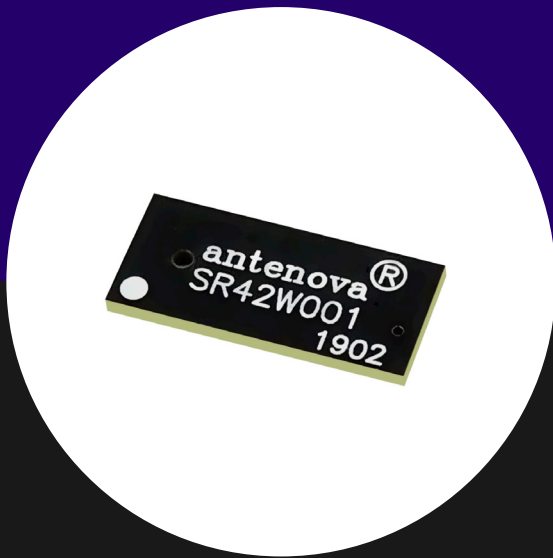

Features

- Antenna for 2.4 – 2.5 GHz and 4.9 – 5.9 GHz applications: Wi-Fi 802.11a/b/g/j/n/ac
- Maintains high performance on device: DFI (Designed For Integration)
- Ultra-compact
- SMD mounting
- Supplied on Tape and Reel

1. Description

Mutica is intended for use with all dual-band Wi-Fi applications. Only requires a small ground plane and integrates into the corner with minimal PCB clearance area. Design centred on being part of the device and not designing the device around the antenna (DFI - Designed for Integration). Ideal for single and MIMO antenna systems.

2. Applications

- Access Points
- Portable Devices
- Headsets
- PC-cards
- Game Consoles
- Set-Top-Box
- Network Devices
- Wearable devices
- MIMO Systems

3. Part number

SR42W001



4. General data

Frequency	2.4-2.5 GHz 4.9-5.9 GHz
Polarization	Linear
Operating temperature	-40°C to 140°C
Environmental condition test	ISO16750-4 5.1.1./5.1.2/5.3.2
Impedance with matching	50 Ω
Weight	<0.5g
Antenna type	SMD
Dimensions	11.3 x 5.0 x 0.8 (mm)

5. RF characteristics

Frequency	2.4-2.5 GHz	4.9-5.9 GHz
Peak gain	2.0dBi	3.0dBi
Average gain (Linear)	-0.5dBi	-2.5dBi
Average efficiency	75%	65%
Maximum return loss	-12dB	-6.0dB
Maximum VSWR	1.5:1	2.70:1

All data measured on Antenova's evaluation PCB
Part No. SR42W001-EVB-1

6. RF performance

6.1. Return loss

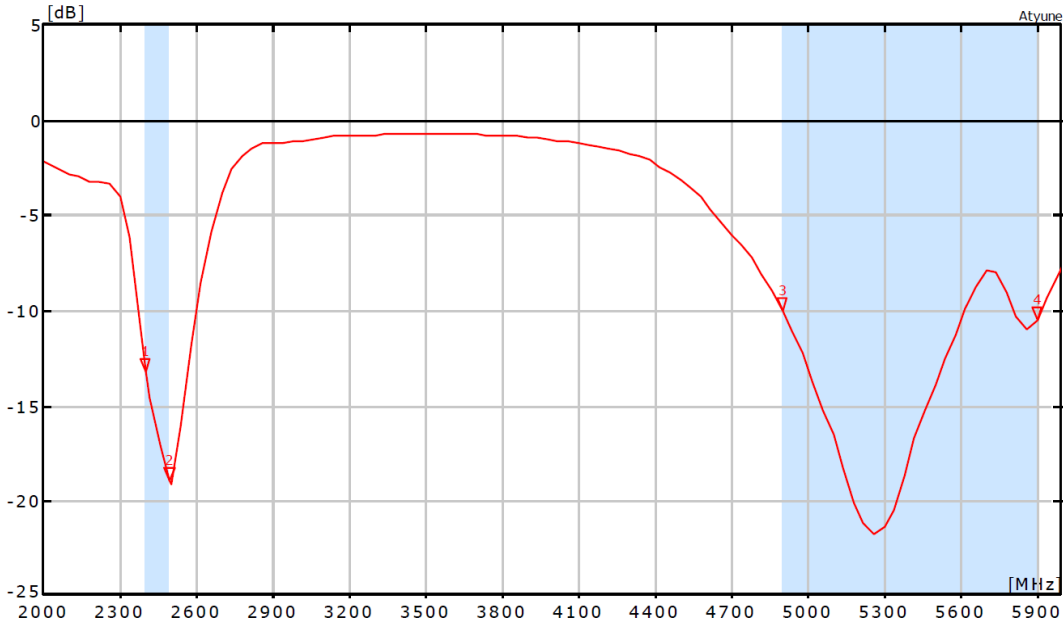

6.2. VSWR

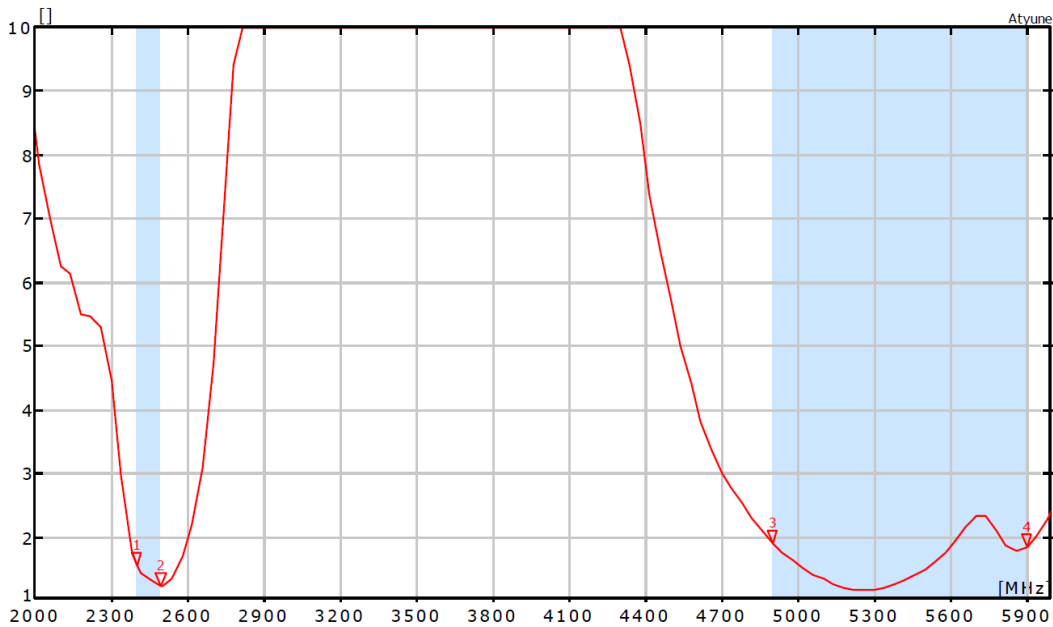

6.3. Efficiency

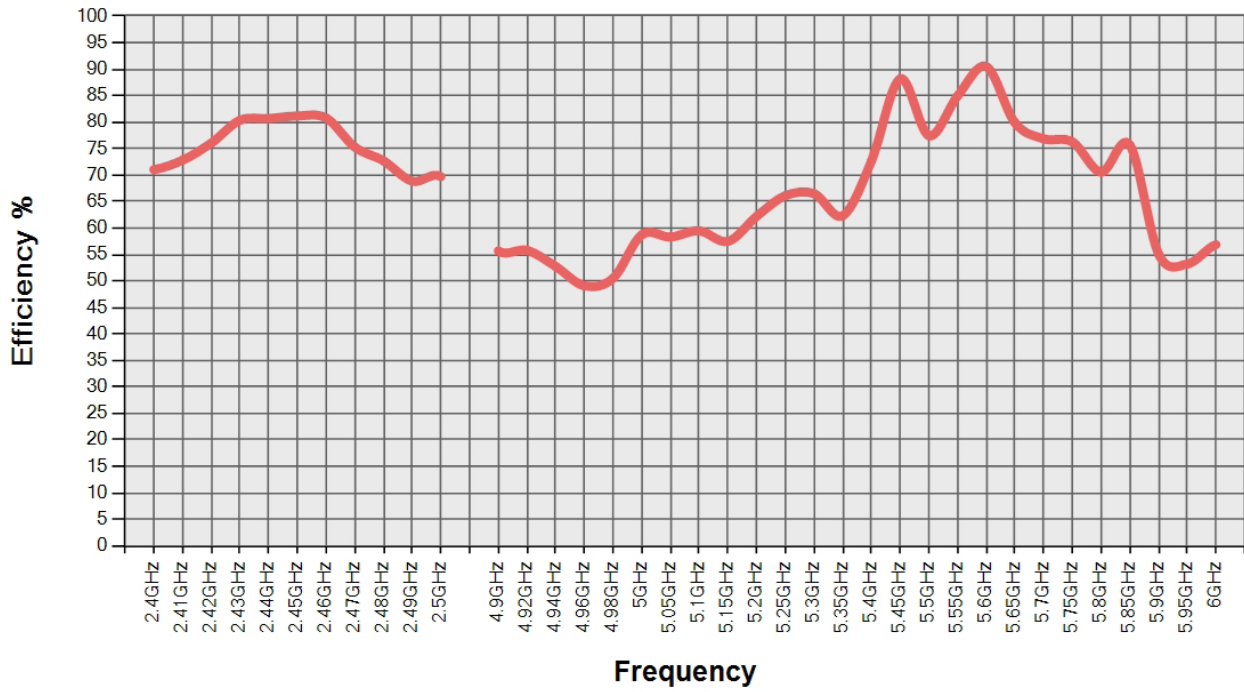

6.4. Antenna pattern

6.4.1. 2400 - 2500 MHz

3D pattern at 2.45 GHz



XY

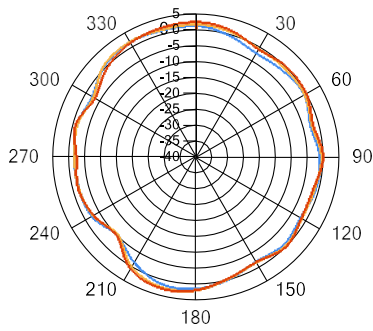

XZ

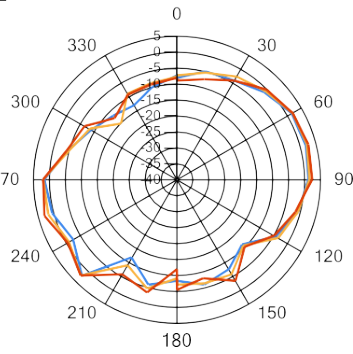

YZ

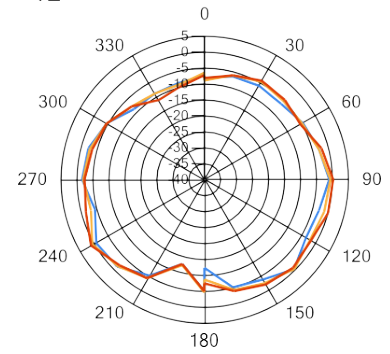

— 2.4GHz — 2.45GHz — 2.5GHz

6.4.2. 4900 - 5900 MHz

3D pattern at 5.45 GHz

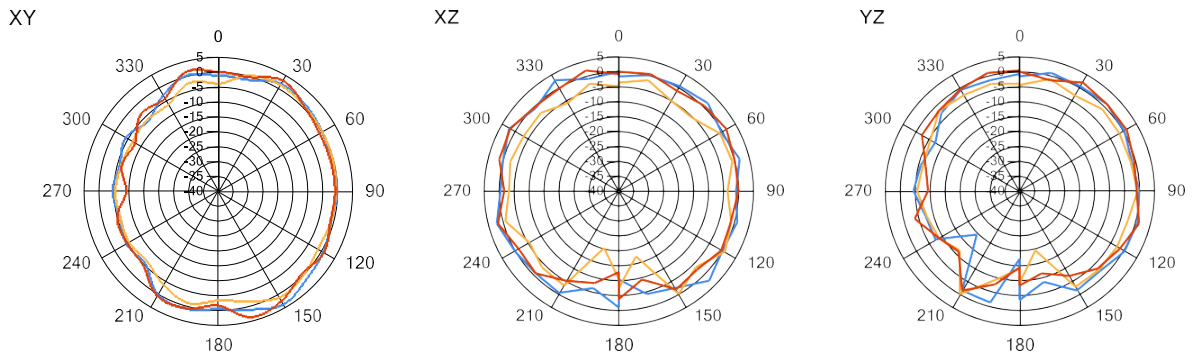
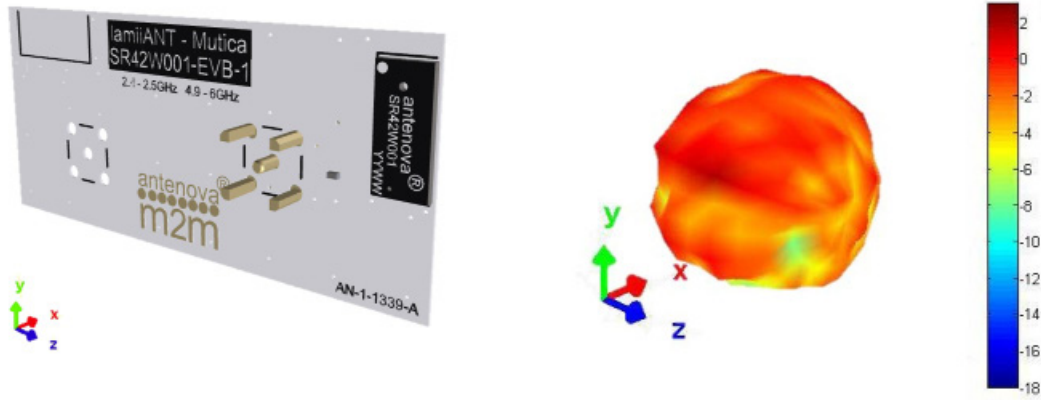

— 4.9GHz — 5.45GHz — 5.95GHz

7. Antenna dimensions

7.1. Dimensions Assembled

Top view

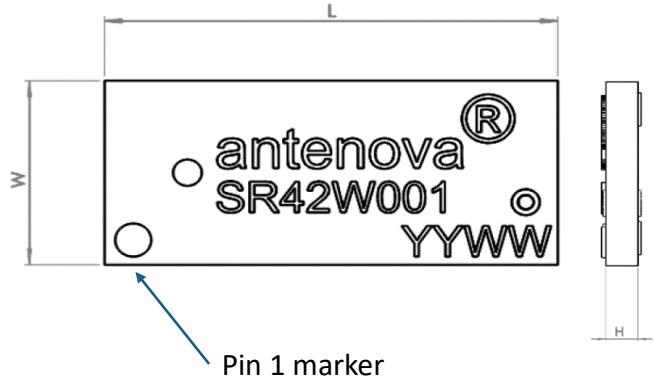

L	W	H
Length	Width	Height
11.3 ±0.1	5.0 ±0.1	0.9 ±0.1 -0.2

All dimensions in (mm)

Bottom view

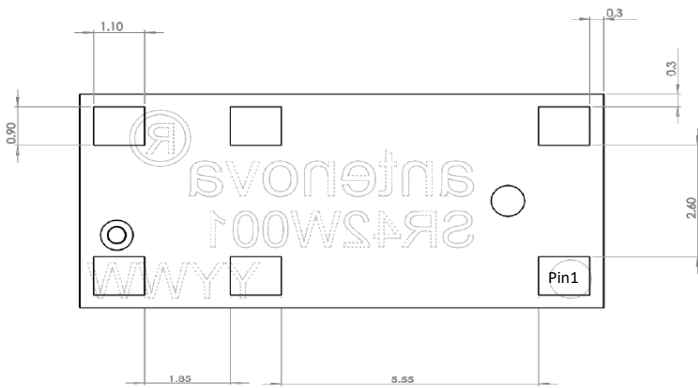

6 solder pads (1.1 x 0.9 mm)

8. Host PCB footprint

The recommended host PCB footprint is below.

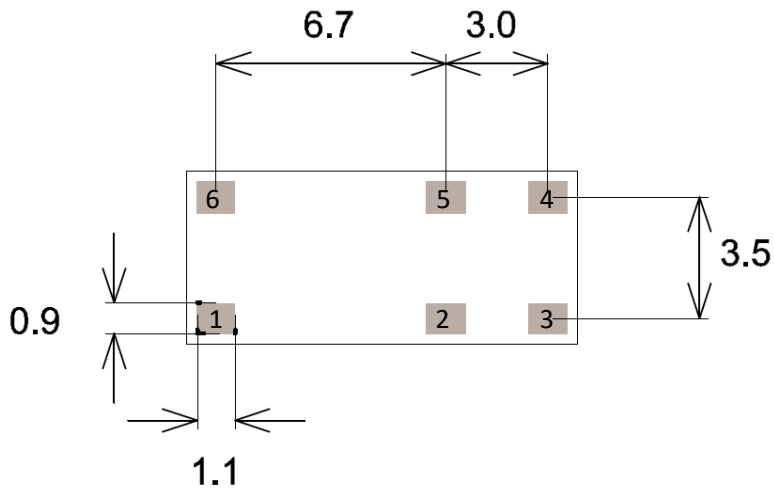

6 copper pads all 1.1 x 0.9 (mm)

*CAD files of antenna footprint are available at www.antenova.com.

9. Schematic

The circuit for the antenna and the matching components is below. The RF feed connection and GND connections are critical to the function of the antenna, and must be followed as shown. This circuit can be used for the circuit capture of the host PCB.

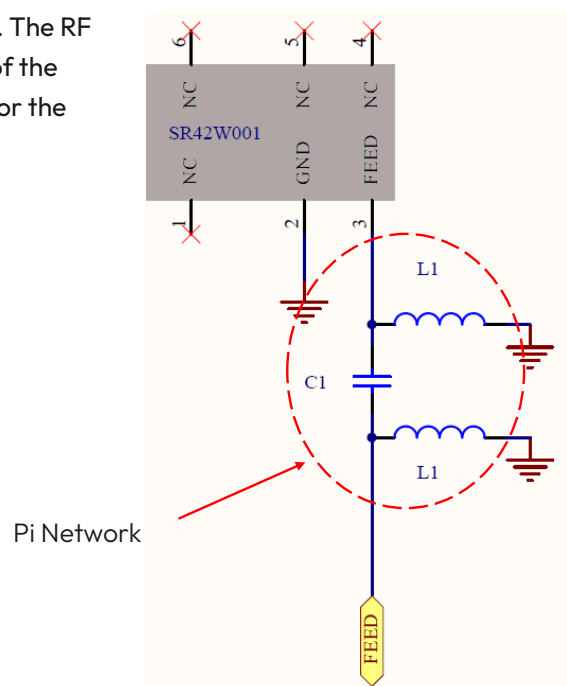

10. Electrical interface

10.1. Transmission line

All transmission lines should be designed to have a characteristic impedance of 50Ω .

- The length of each transmission lines should be kept to a minimum
- All other parts of the RF system like transceivers, power amplifiers, etc, should also be designed to have a 50Ω impedance

A co-planar transmission line can be designed using an online transmission line calculator tool, such as:

<https://blog.antenova.com/rf-transmission-line-calculator>

The PCB thickness, copper thickness and substrate dielectric constant are entered, then the tool calculates the transmission line width and gaps on either side of the track to give a 50Ω impedance.

10.2. Matching circuit

The antenna requires a matching circuit that must be optimized for each product. The matching circuit will require up to three components and the following pad layout should be designed into the device so the correct circuit can be installed.

The Pi matching network must be placed close to the antenna feed to ensure it is more effective in tuning the antenna.

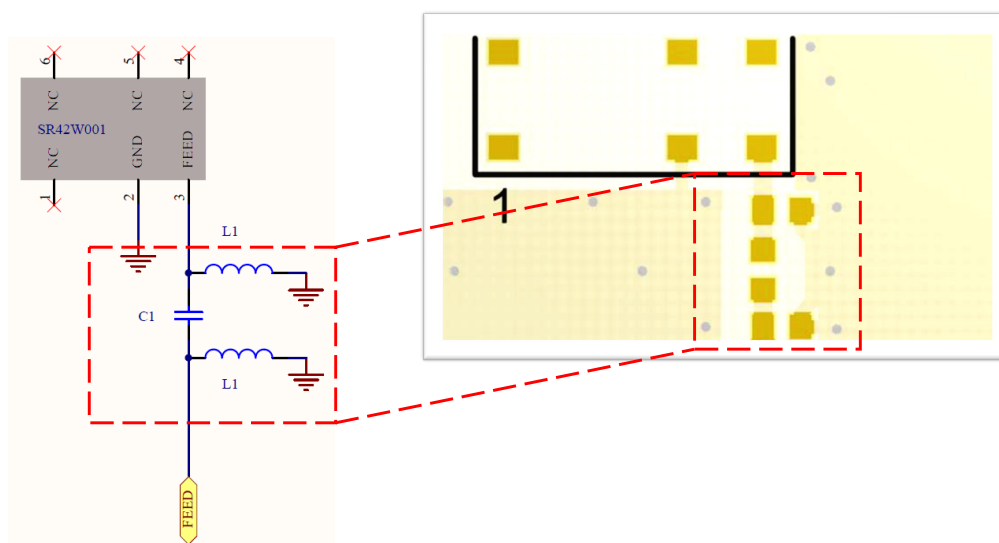

11. Antenna integration guide

We recommend the following during the design phase to maximise antenna performance and minimize noise:

- Minimum 4 layer PCB
- Route signals and power internally where possible
- Flood all layers with ground
- Knit ground on all layers together with plenty of vias

Follow placement guidance carefully, in addition Antenova provide technical support to help you through all stages of your design. Register for an account on <https://ask.antenova.com/> to access technical support.

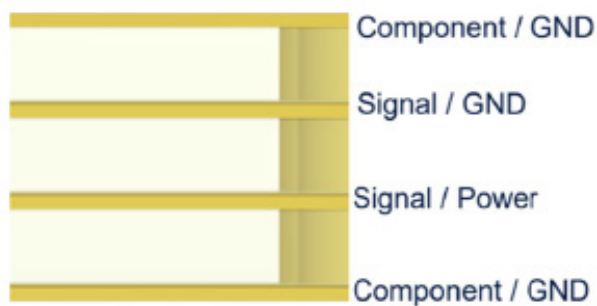

11.1. Antenna placement

Whichever the host PCB size used, the antenna should be placed into the PCB corner. Ideally Pin 1 should be closest to the PCB edge.

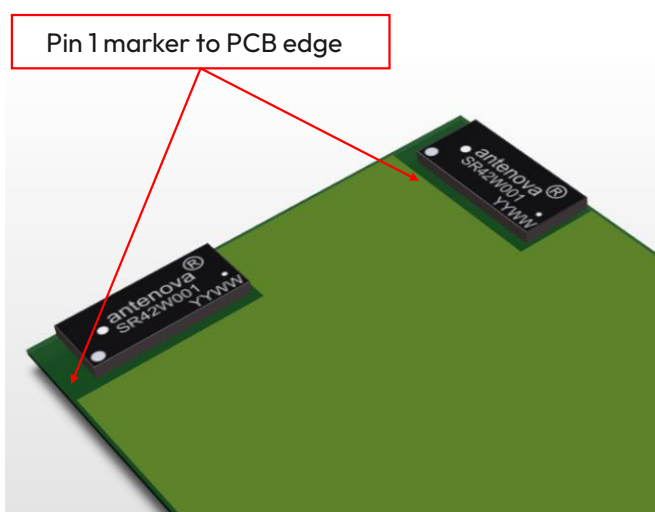

The antenna requires a copper clearance on all PCB layers under the antenna section. The clear-out area is defined below. The clearance is minimal but must be followed for the antenna to function correctly.

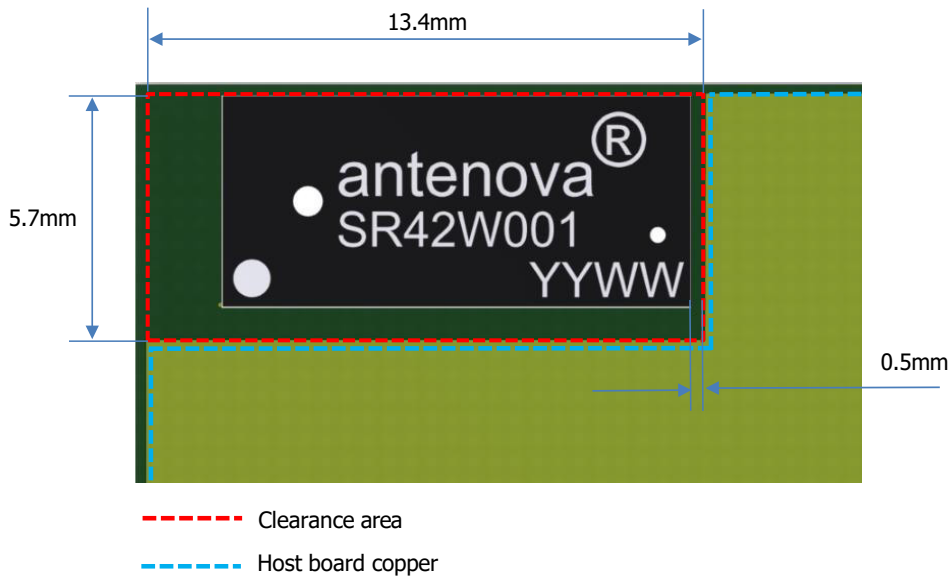

For locations that are not on the corner the following clearances are required from each side of the antenna to GND.

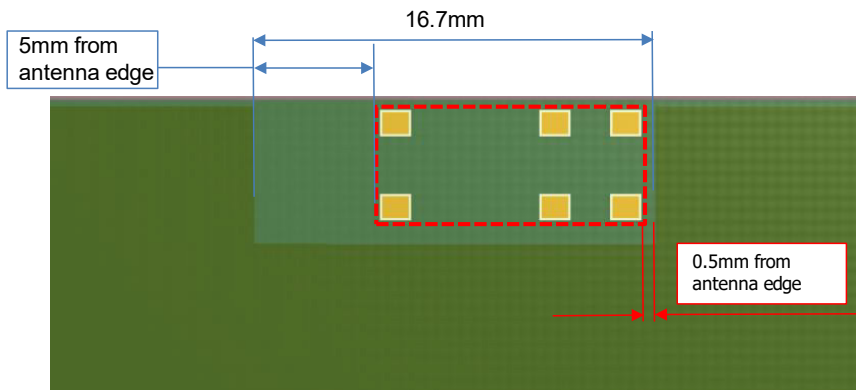

Centre PCB placement example

11.2. Host PCB layout

The host PCB must ensure the footprint and clearance meets the antenna specification. An example of the PCB layout shows the antenna footprint with clearance. The antenna uses solder mask defined pads. Pin 2(GND) is shown directly connecting to the GND in the shortest route. The feed connects to the matching circuit close to the antenna.

Example host layout

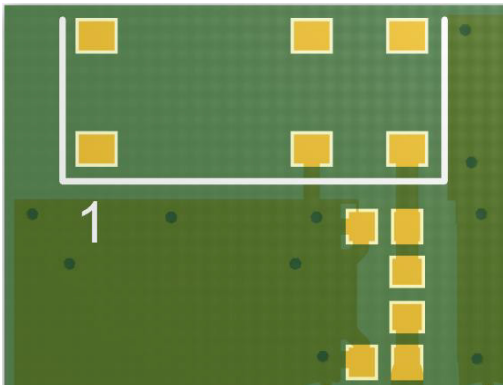

Below shows the antenna footprint and clearance through all layers on the PCB. Only the antenna pads and connections to feed and GND are present within the antenna area.

Example host layout

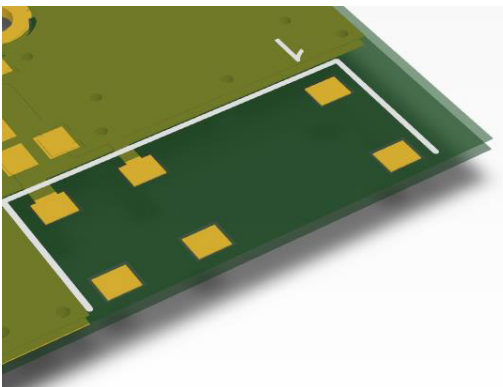

12. MIMO application example

Mutica works well in multiple antenna systems with simple integration to ensure good isolation between antennas. Below is an example of a 2 X MIMO system.

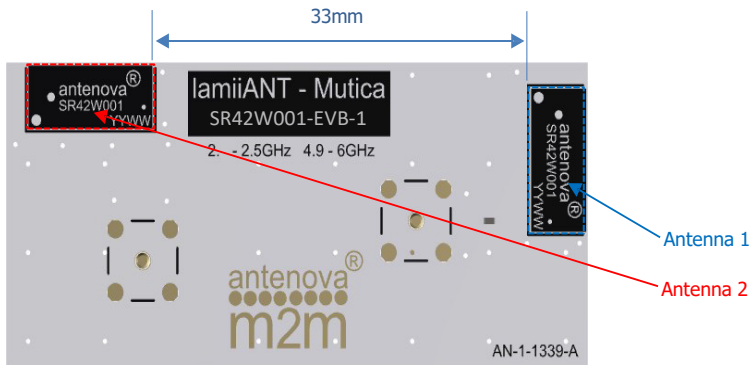

Two antennas placed perpendicular to each other. Both antennas were optimised and matched for the same bands using the Antenna evaluation PCB. An S21 measurement between these antennas shows good isolation of <15dB minimum.

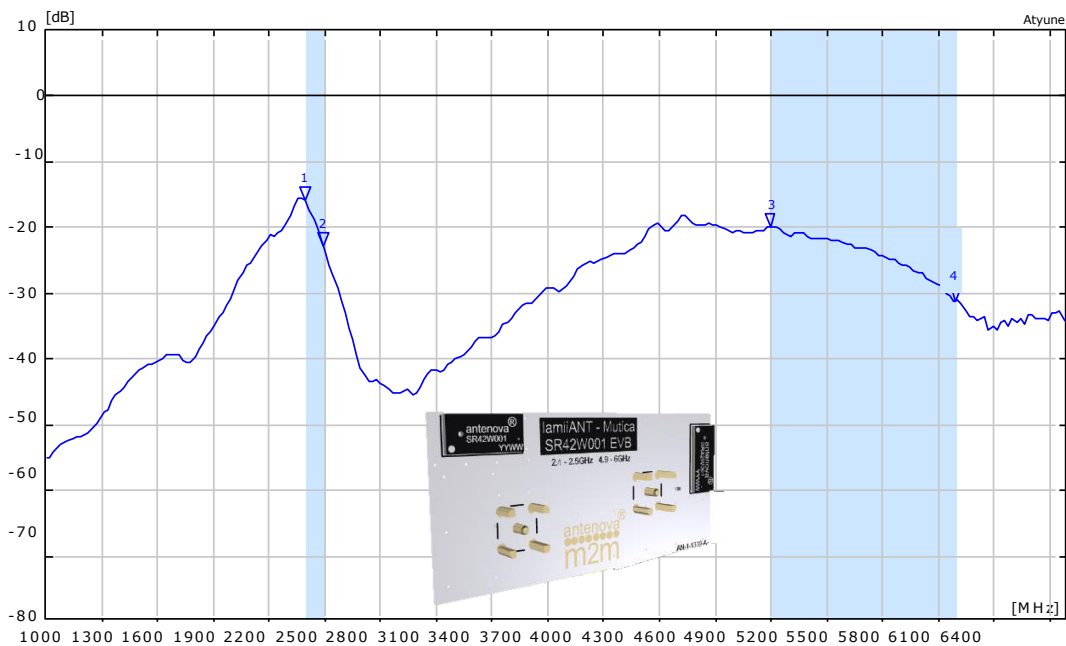

13. Reference board

The reference board has been designed for evaluation purposes of SR42W001 includes a SMA female connector.

(Part number SR42W001-EVB-1)

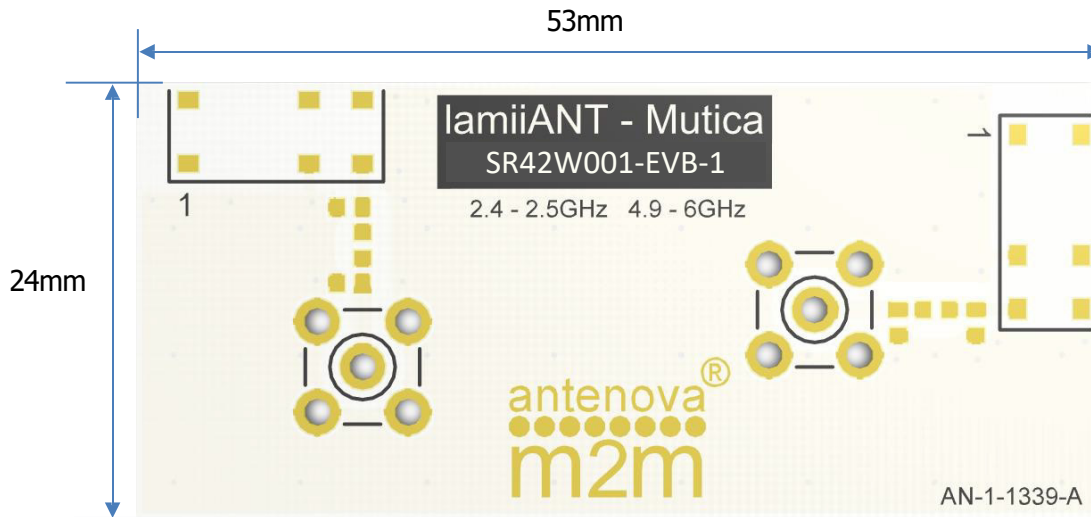

To order a reference board please see antenna.com

13.1. Reference board matching circuit

The reference board has been designed in order to evaluate the SR42W001 and is fitted with an SMA female connector.

Designator	Type	Value	Description
C1	Capacitor	1pF	Murata GJM15 series
L1	Inductor	15nH	Murata LQG15HN series
L2	Inductor	Not fitted	Not fitted

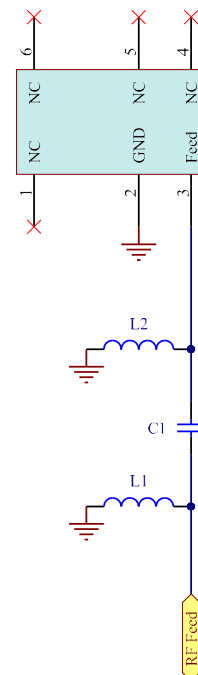

14. Soldering

This antenna is suitable for lead free soldering. The reflow profile should be adjusted to suit the device, oven and solder paste, while observing the following conditions:

- For leaded soldering, the maximum temperature should not exceed 240 °C.
- For lead free soldering, a maximum temperature of 255 °C for no more than 20 seconds is permitted.
- The antenna should not be exposed to temperatures exceeding 120 °C more than 3 times during the soldering process.

15. Hazardous material regulation conformance

The antenna has been tested to conform to RoHS and REACH requirements. A certificate of conformance is available from Antenova's website.

16. Packaging

16.1. Optimal storage conditions

Temperature	-10°C to 40°C
Humidity	Less than 75% RH
Shelf life	24 Months
Storage place	Away from corrosive gas and direct sunlight
Packaging	Reels should be stored in un-opened sealed manufacturer's plastic packaging.

Note: Storage of open reels of antennas is not recommended due to possible oxidization of pads on antennas. If short term storage is necessary, then it is highly recommended that the bag containing the antenna reel is re-sealed and stored in conditions as described in the tabel above.

The shelf life of the antenna is 2 years provided the factory seal on the package has not been broken.

16.2. Tape characteristics

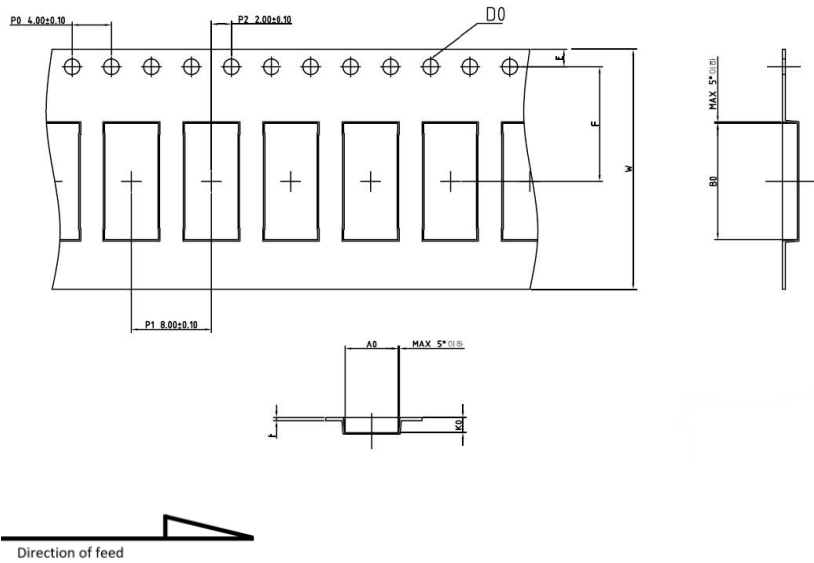

Do	Ao	Bo	PO	P1	P2
1.55 +0.1	5.30 ± 0.1	11.605 ± 0.1	4.00 ± 0.1	8.00 ± 0.1	2.00 ± 0.1

E	F	W	K0
1.75 ± 0.1	11.50 ± 0.1	24.00 ± 0.3	1.40 ± 0.1

All dimensions in (mm)

16.3. Reel dimensions

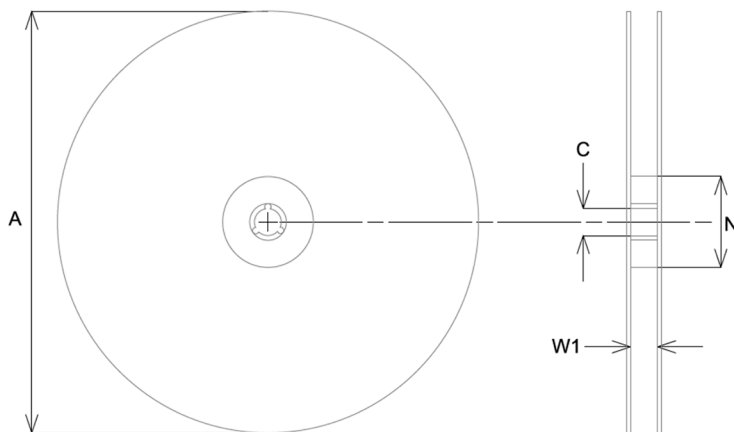

A	C	N	W1
178.0 ± 2.0	13.2 ± 0.5	60.0	14.0

All dimensions in (mm)

Quantity	Leading space	Trailing space
1000 pcs / reel	16 blank antenna holders	24 blank antenna holders

16.4. Box dimensions

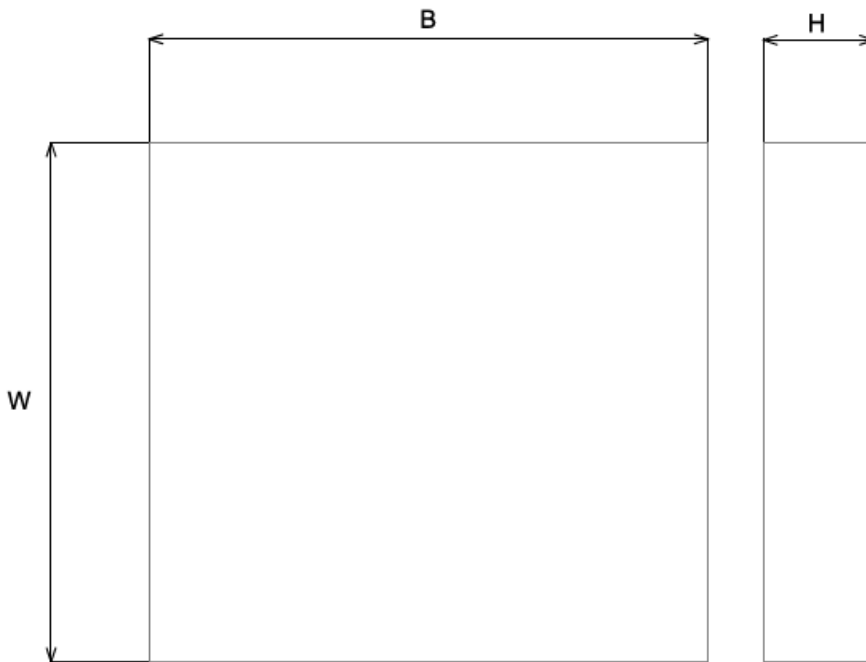

Width (W)	Breadth (B)	Height (H)
203mm	188mm	40mm

16.5. Bag properties

Reels are supplied in protective plastic packaging.

16.6. Reel label information

Antenova Limited **antenova**
 www.antenova.com
 DESCRIPTION: MUTICA 
 PART NUMBER: SR42W001 
 QTY: 1,000 pcs 
 DATE CODE: YYWW 





Quality statements

Antenova's products conform to REACH and RoHS legislation. For our statements regarding these and other quality standards, please see [antenova.com](https://www.antenova.com).

Antenova reserves all rights to the contents of this document. Antenova gives no warranties based solely on the accuracy or completeness of the contents of this document and reserves the right to make changes to the specifications of the products described herein at any time and without notice.



Datasheet version

3.01 released 29th OCT 2025

Antenna design, integration and test resources

Product designers – the details contained in this datasheet will help you to complete your embedded antenna design. Please follow our technical advice carefully to obtain optimum antenna performance.

We aim to support our customers to create high performance wireless products. You will find a wealth of design resources, calculators and case studies to aid your design on our website.

Antenova's design laboratories are equipped with the latest antenna design tools and test chambers. We provide antenna design, test and technical integration services to help you complete your design and obtain the required certifications.

If you cannot find the antenna you require in our product range, please contact us to discuss creating a custom antenna to meet your exact requirements.

Share knowledge with RF Experts around the world

ask.antenova is a global forum for
designers and engineers working with
wireless technology

[Visit Ask.Antenova](https://ask.antenova.com)

Visit [antenova.com](https://www.antenova.com)

**Order antenna samples and
evaluation boards, and read our
antenna resources**

[Visit antenova.com](https://www.antenova.com)

Request a volume quotation for antennas:

[**sales@antenova.com**](mailto:sales@antenova.com)

+44 (0) 23 9400 1023

Global headquarters

**Antenova Ltd, 7 The Briars,
Waterberry Drive, Waterlooville,
Hampshire, PO7 7YH**